

Jungle Climber Little Monkeys – Spider Monkey

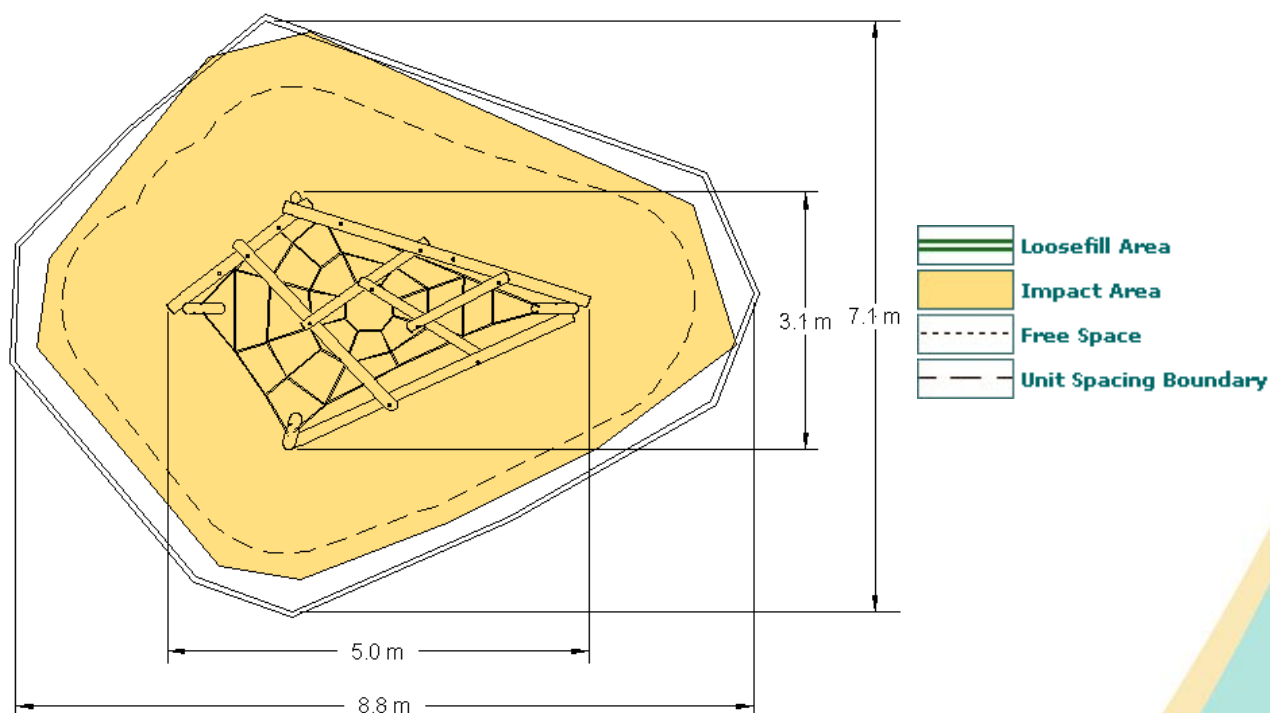
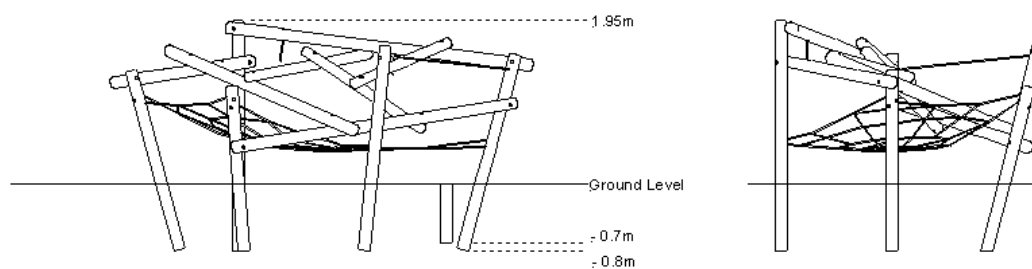

Technical Information

Equipment Dimensions

Length / Width / Height **5.0m x 3.1m x 1.95m**

Surfacing and Area Required

Minimum Space Required L/W/H **8.8m x 7.1m x 4.4m**

Max Gradient Of Ground **1:50**

Free Height Of Fall **1.95m**

Impact Area **34.73m²**

Loosefill At 350mm **14m³**

Bark / Cushionfall / Sand **50**

Grasslok **50**

Installation Information

Overall Weight **331kg**

Heaviest Part **47kg**

Largest Part **3.8m x 0.14m x 0.14m**

Longest Part **3.8m**

Concrete Required **0.55m³**

COMPLIES TO BS EN 1176