

Movers – Rota Rock

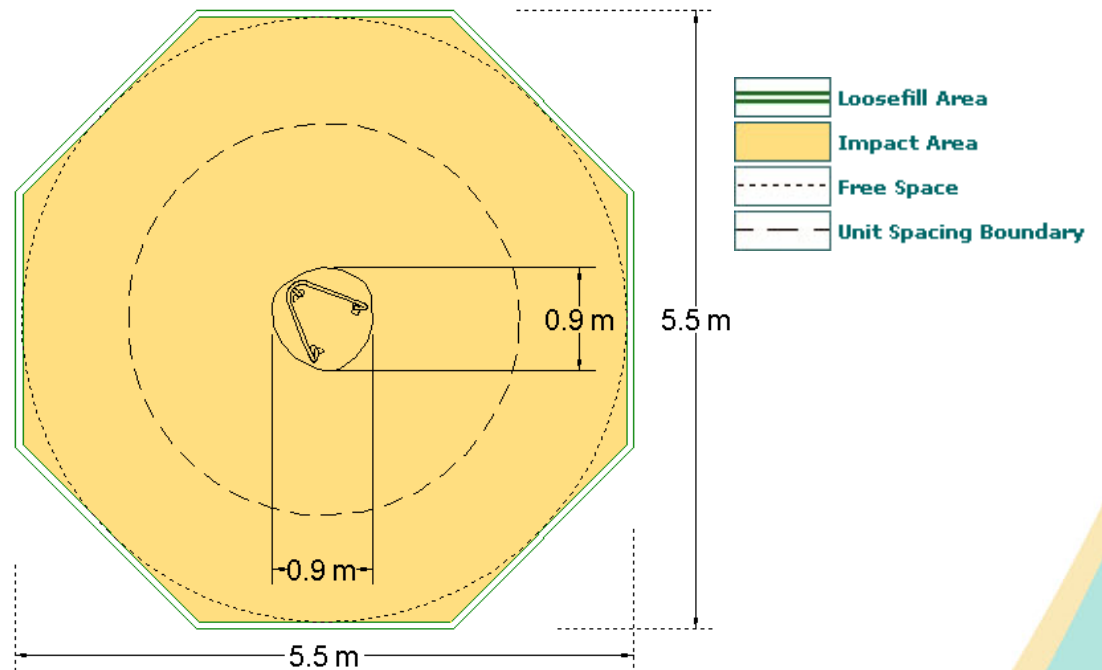
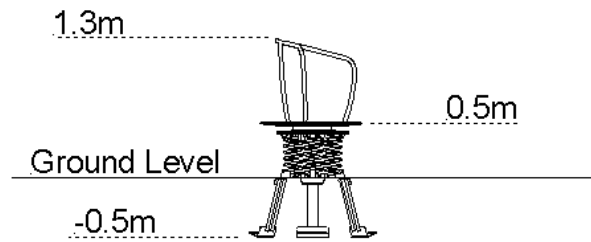

Technical Information

Equipment Dimensions

Length / Width / Height 0.9 x 0.9 x 1.3m

Surfacing and Area Required

Minimum Space Required L/W/H 5.5 x 5.5 x 2.7m

Max Gradient Of Ground 1in30

Free Height Of Fall 1.0m

Impact Area 24.16m²

Loosefill At 250mm 6m³

Bark / Cushionfall / Sand

Grasslok Tiles 36m²

Installation Information

Overall Weight 110 Kg

Heaviest Part 25 Kg

Largest Part 1.0 x 0.8 x 0.5m

Longest Part 1.0m

Concrete Required 0.3m³

KITEMARKED TO BS EN 1176