

Springers – Quad Rider

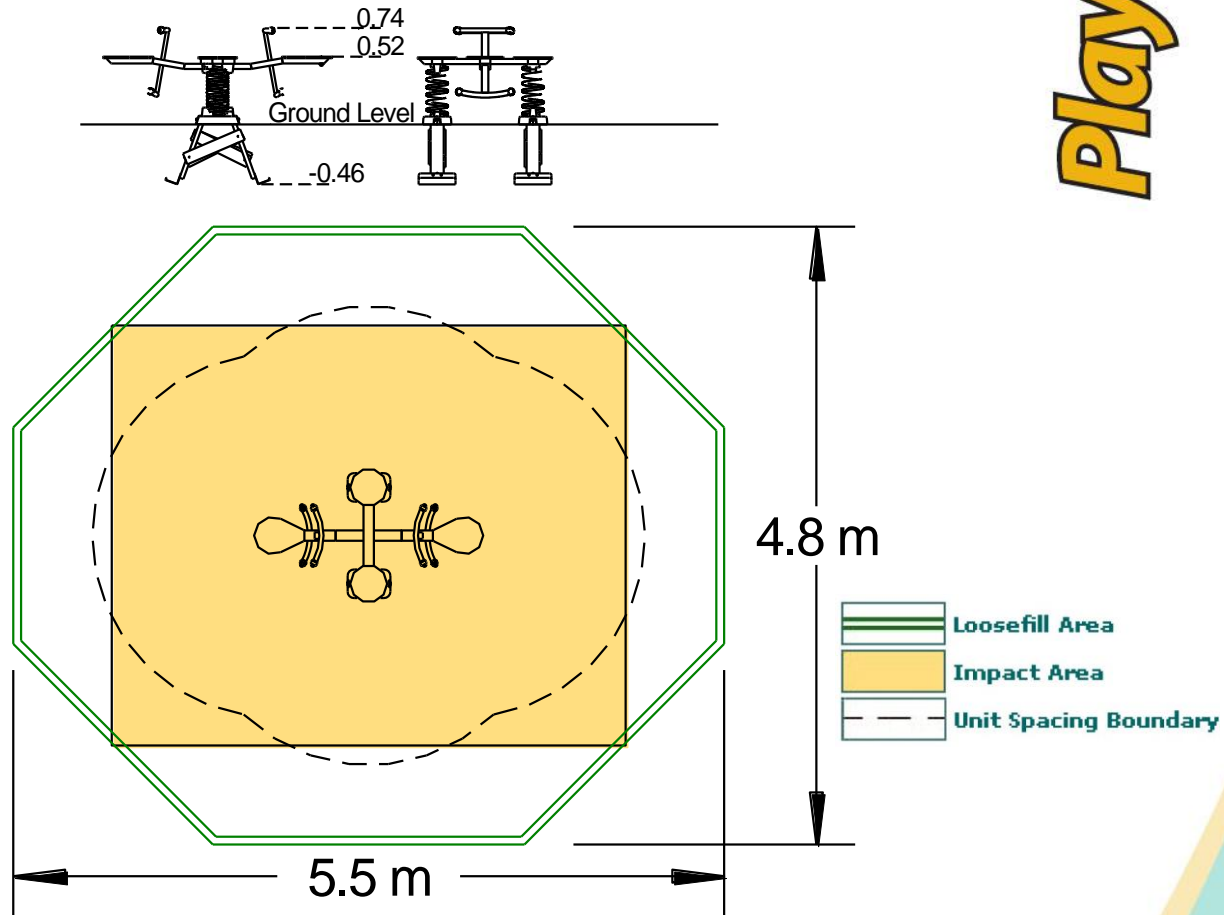

Technical Information

Equipment Dimensions

Length / Width / Height **1.8m x 1.1m x 0.8m**

Surfacing and Area Required

Minimum Space Required L/W/H **5.5m x 4.8m x 2.0m**

Max Gradient Of Ground **1 in 20**

Free Height Of Fall **0.9m**

Impact Area **14.53m²**

Loosefill At 150mm **6m³**

Bark / Cushionfall / Sand

Grasslok Tiles **18m²**

Installation Information

Overall Weight **50kg**

Heaviest Part **27kg**

Largest Part **1.8m x 1.1m x 0.6m**

Longest Part **n/a**

Concrete Required **0.12m³**

KITEMARKED TO BS EN 1176