

# Big City Plus - Salt Lake City Plus



-  **Option A**  
Dark Blue & Orange  
(shown)
-  **Option B**  
Purple & Yellow
-  **Option C**  
All Green

**Code – BC/SLC\*1**

**Age**

5-12 years

**Materials**

Stainless Steel  
Compact Grade Laminate (CGL)  
Nylon Steel Cored Rope  
Various Plastic Mouldings  
LLDPE Slide

**A junior modular tower system comprising of:**

- Square Tower (1.5m)
- Slide (1.5m)
- Fireman's Pole (1.5m)
- Climbing Wall (1.5m)
- Rope Climb (1.5m)

## Technical Information

### Equipment Dimensions

Length / Width / Height **3.8m x 2.3m x 3.1m**

### Surfacing and Area Required

Recommended Minimum Space  
L/W/H **7.7m x 6.1m x 4.3m**

Max Gradient of Ground **1 in 50**

Free Height of Fall **1.5m**

Impact Area **26.58m<sup>2</sup>**

Synthetic Area  
(i.e. EPDM / Wet Pour / Synthetic Grass etc.) **27.69m<sup>2</sup>**

Loosefill at 250mm  
(i.e. Bark / Cushionfall / Sand) **9m<sup>3</sup>**

GrassLok Tiles **39m<sup>2</sup>**

### Installation Information

SGF

SF (if different)

Installation Time **2 Persons 9 Hours**

Overall Weight **2999kg**

Heaviest Part **40kg**

Largest Part **3.Xm x 0.6m x 0.6m**

Longest Part **3.0m**

Concrete Required **0.34m<sup>3</sup>** **0.52m<sup>3</sup>**

Certified to ASTM F1487

[Click here for more information & downloads](#)



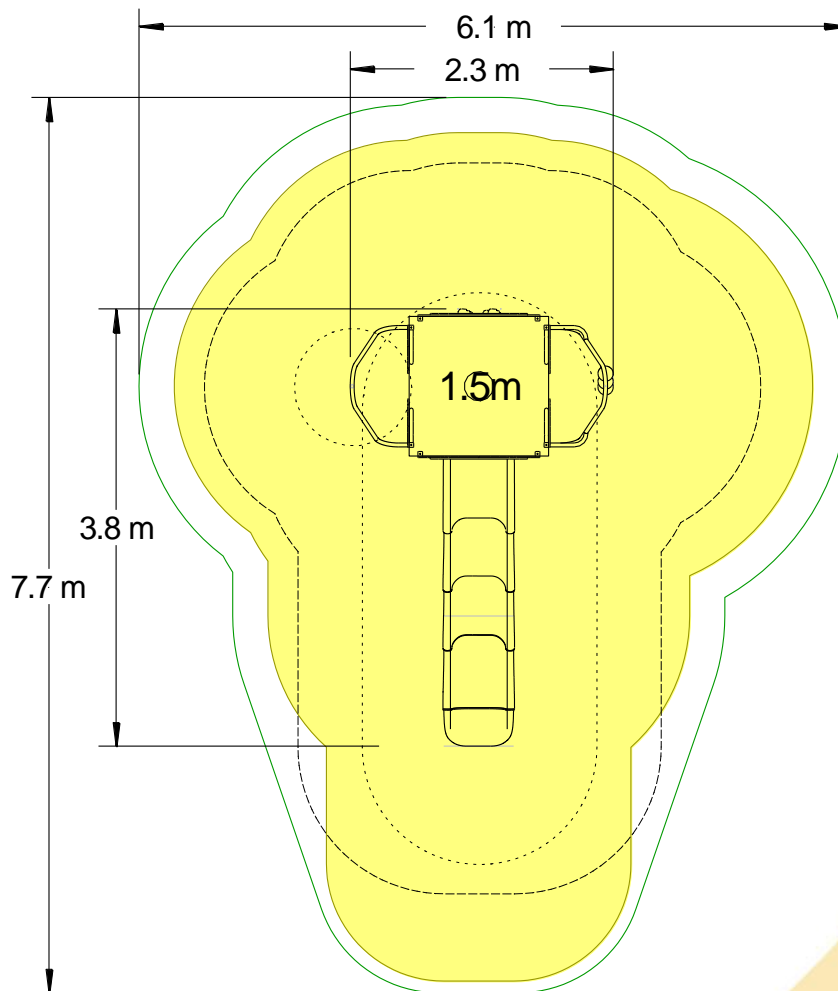
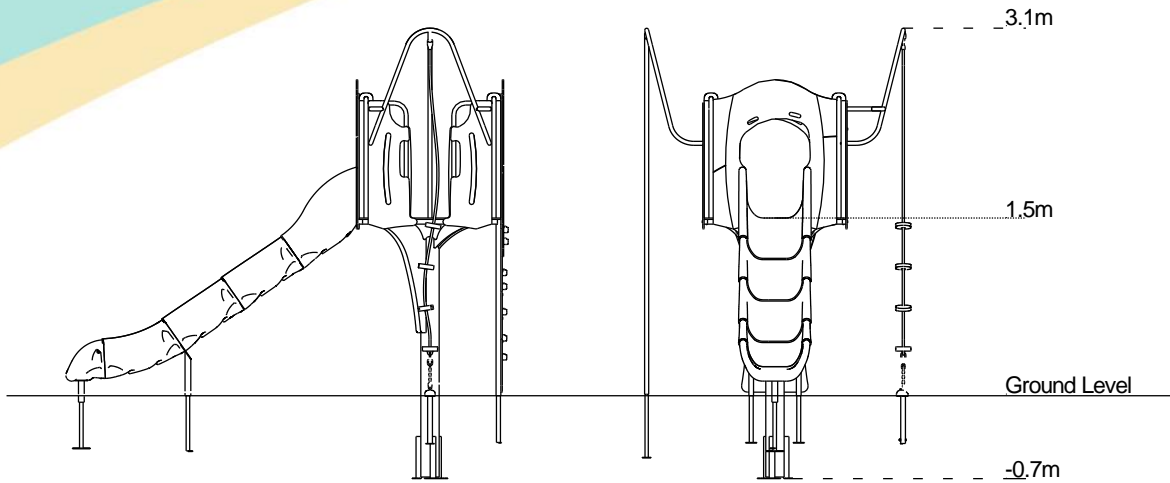

-  Recommended Minimum Space
-  Impact Area
-  Free Space
-  Unit Spacing Boundary

[Click here for more information & downloads](#)

