

Climbers – Cone Climber 3.0m

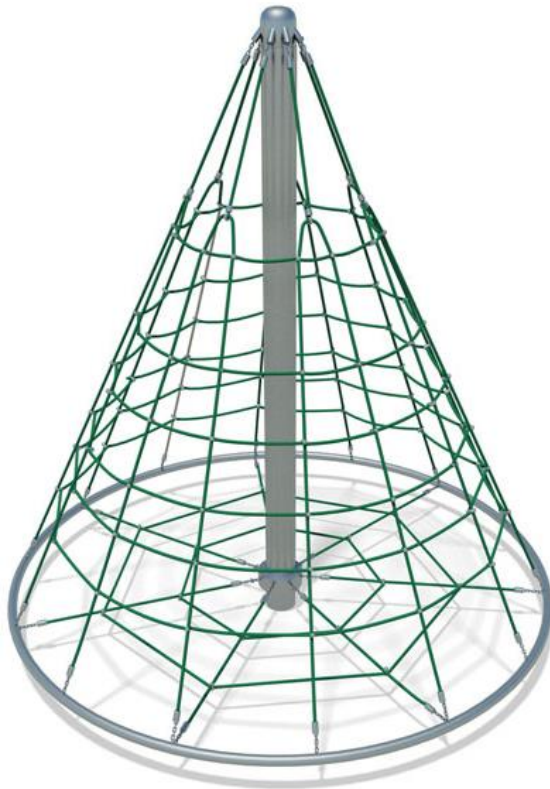

Code –
NETS0007

Age

3-12 years

Materials

Stainless Steel

Sealed Bearings

Steel Cored Rope

Product Description

Rotating net play will have children in a spin! The Cone Climber is great for multi-play as they climb to the top of the rotating net.

Technical Information

Equipment Dimensions

Length / Width / Height **2.4m x 2.4m x 3.0m**

Surfacing and Area Required

Minimum Space Required L/W/H **6.52m x 6.52m x 4.1m**

Max Gradient of Ground **1 in 50**

Free Height of Fall **2.1m**

Impact Area - Wetpour **33.94m²**

Loosefill At 350mm **12m³**

Bark / Cushionfall / Sand **45**

1m x 1m Rubber Tiles **45**

Installation Information

Overall Weight **160kg**

Heaviest Part **100kg**

Largest Part **2.4m x 2.4m x 0.2m**

Longest Part **4.1m**

Concrete Required **0.72m³**

TUV CERTIFIED TO BS EN 1176

[Click here for more information & downloads](#)



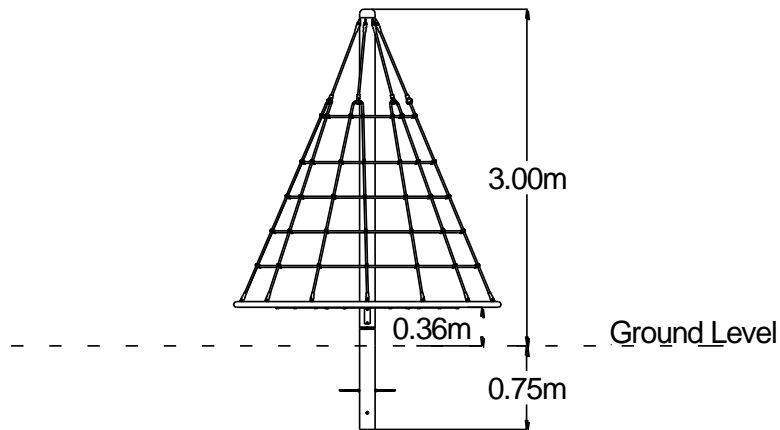

- Impact Area
- Free Space
- Synthetic Area

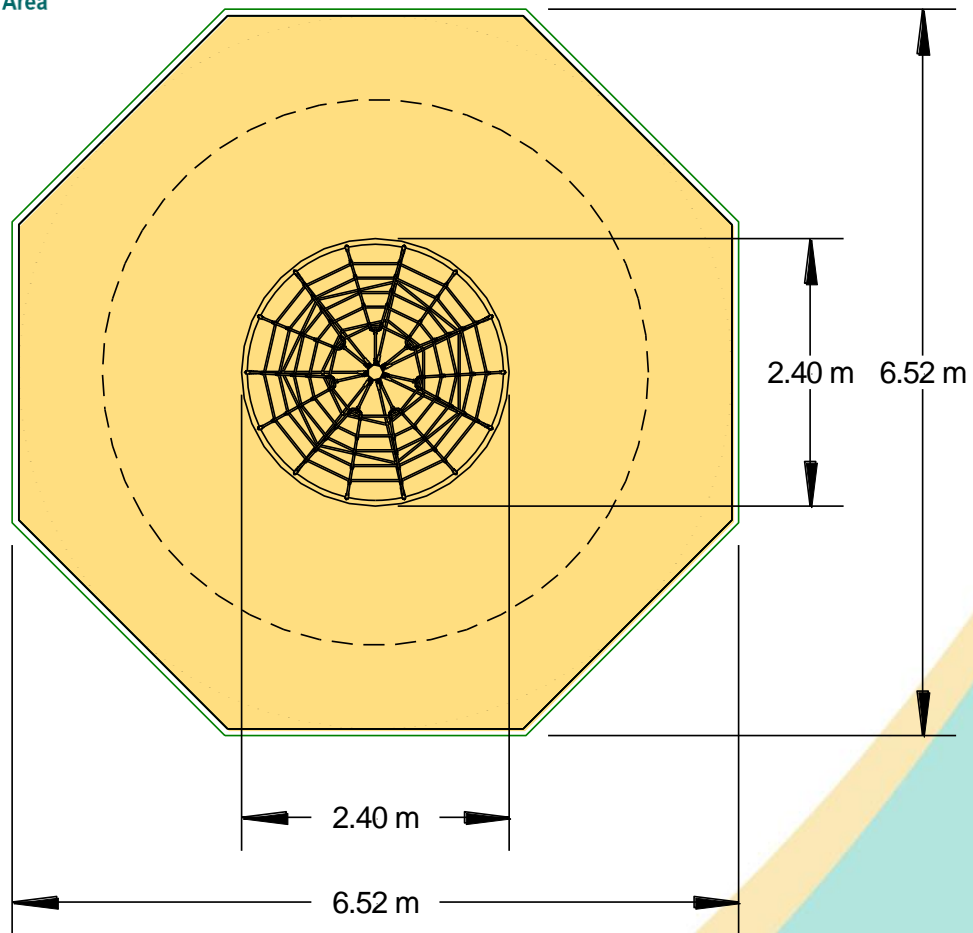

[Click here for more information & downloads](#)

