

Springers – Pony Seesaw

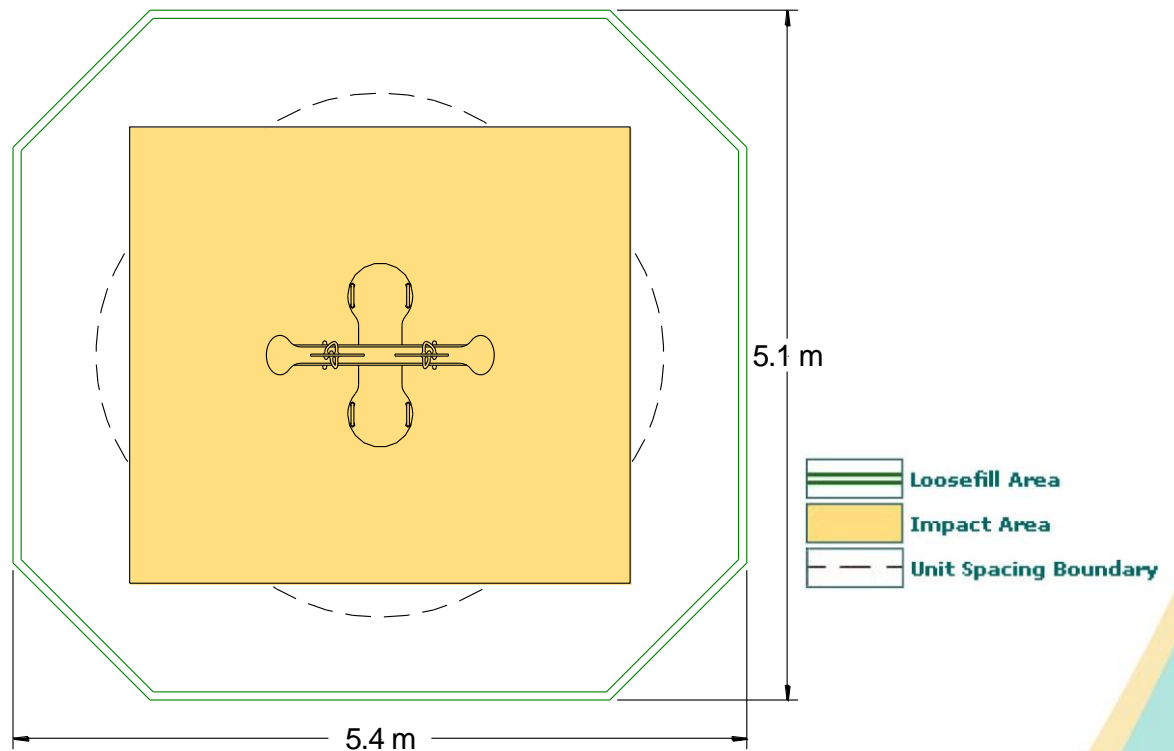
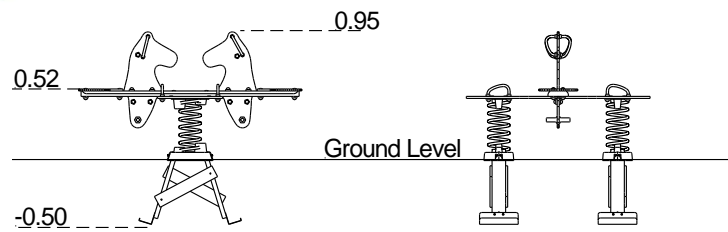

Technical Information

Equipment Dimensions

Length / Width / Height	1.7m x 1.36m x 0.95m
Surfacing and Area Required	
Minimum Space Required L/W/H	5.4m x 5.1m x 3.3m
Max Gradient of Ground	1 in 20
Free Height of Fall	0.85m
Impact Area	12.4m ²
Loosefill at 150mm	6m ³
Bark / Cushionfall / Sand	
Grasslok Tiles	14m ²

Installation Information

Overall Weight	67kg
Heaviest Part	20kg
Largest Part	1.69m x 0.3m x 0.75m
Longest Part	n/a
Concrete Required	0.12m ³

TUV CERTIFIED TO BS EN 1176