

# Training Buddies – Squat

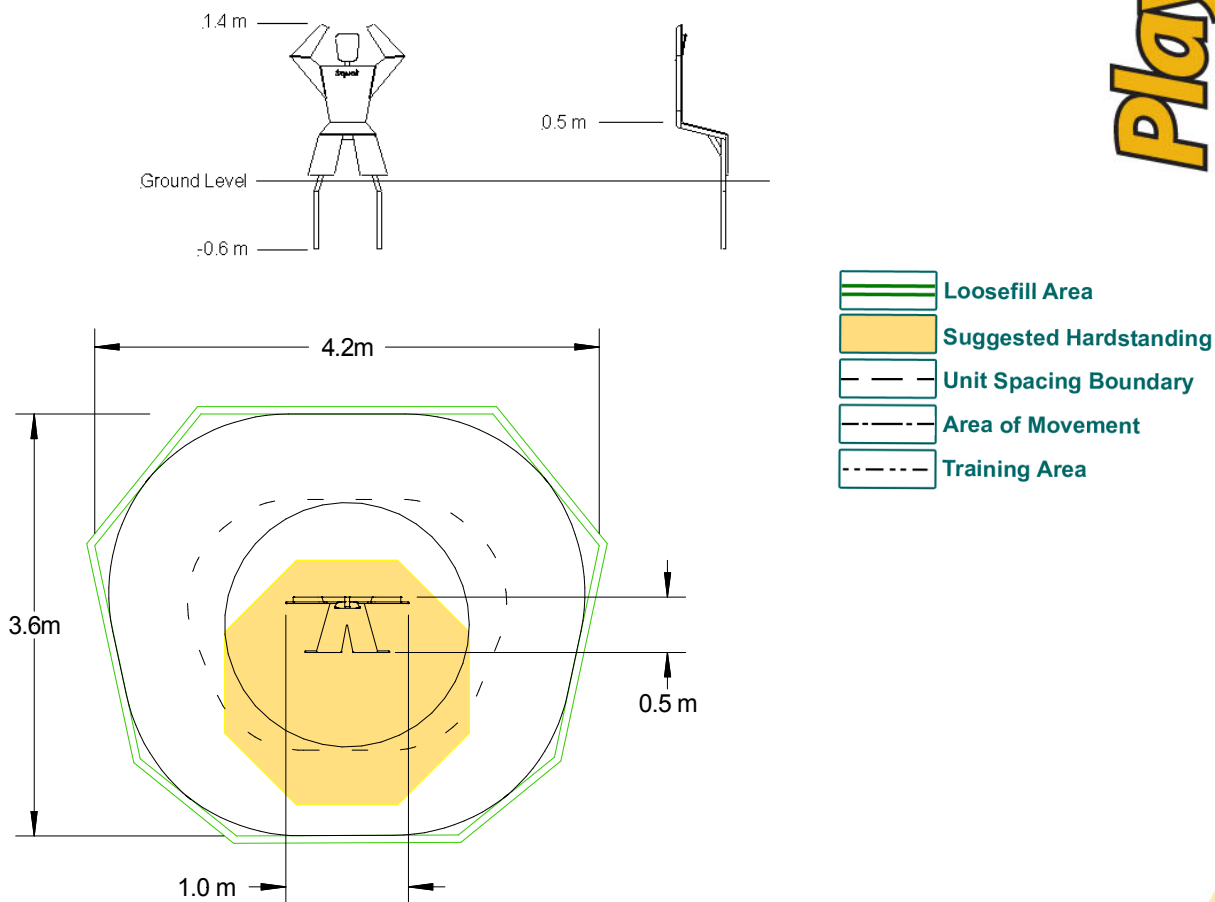

## Technical Information

### Equipment Dimensions

Length / Width / Height **1.0m x 0.5m x 1.4m**

### Surfacing and Area Required

Minimum Space Required L/W/H **4.2m x 3.6m x 3.9m**

Max. Gradient Of Ground **1in30**

Free Height Of Fall **n/a**

Suggested Hardstanding **3.31m<sup>2</sup>**

Loosefill at 150mm **2m<sup>3</sup>**

Bark / Cushionfall / Sand **9m<sup>2</sup>**

Grasslok **9m<sup>2</sup>**

### Installation Information

Overall Weight **28kg**

Heaviest Part **28kg**

Largest Part **1.0m x 0.5m x 2.0m**

Concrete Required **0.16m<sup>3</sup>**

Suitable for users aged + 14yrs old, measuring at least 1.40m in height.