

Climbers – Swing Bars (CIX1)

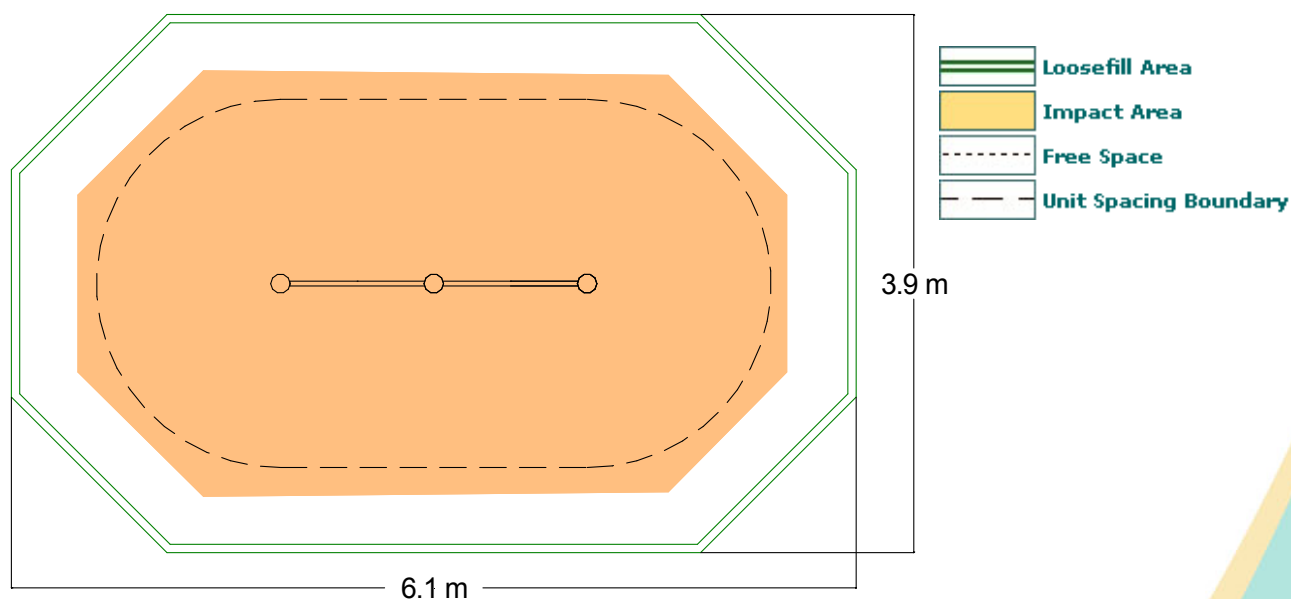
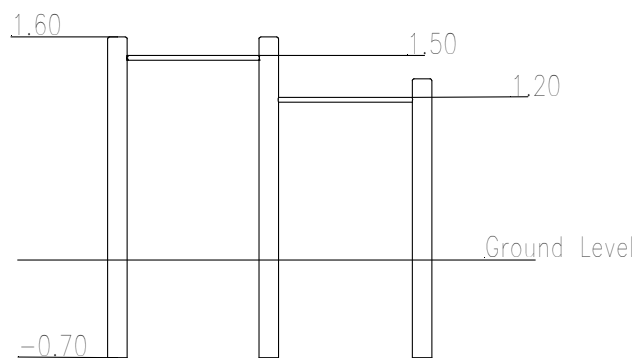

Technical Information

Equipment Dimensions

Length / Width / Height **2.3m x 0.14m x 1.6m**

Surfacing and Area Required

Minimum Space Required L/W/H **5.9m x 3.7m x 2.8m**

Max Gradient of Ground **1 in 30**

Free Height of Fall **1.5m**

Impact Area **13.82m²**

Loosefill (Bark / Cushionfall / Sand) at 300mm **5m³**

Grasslok Tiles **21m²**

Installation Information

Overall Weight **85kg**

Heaviest Part **28kg**

Largest Part **2.3m x 0.14m Ø**

Longest Part **2.3m x 0.14m Ø**

Concrete Required **0.16m³**



KITEMARKED TO BS EN 1176